



K275Y002

Description

K275Y002 is an actuator with constant temperature regulator and it is designed for mounting on R296/R297 mixing valves. It controls fixed delivery temperature both heating and cooling systems (without humidity control), in "stand-alone" functioning.

The actuator has a fixed angle rotation of 90° and possibility of manual control.

With DIP switches inside actuator is possible to set the following parameters:

- Direction of rotation (counterclockwise CCW / clockwise CW)
- Different temperature ranges depending on the application
- Reaction factor x1/x10

Typical applications:

- Maintaining a constant temperature in boiler heating circuit
- Underfloor heating applications, industrial processes, heat accumulators
- Domestic hot water systems or swimming pools

Versions and product codes

Product code	Power supply	For use with mixing valves
K275Y002	24 V - 50 Hz	R296, R297

Spare parts

Mixing valve	Spare kit for installation on the valve
R296	P275Y003
R297 3/4", 1", 1-1/4"	P275Y004
R297 1-1/2", 2"	P275Y001
R297 Flanged	P275Y001

Technical data

Electrical data

- Supply voltage: 24 Vac, 50 Hz, ± 10 % (230 Vac, 50 Hz with adapter included)
- Power: 5 VA
- Connection cable: 2 x 0,5 mm²; length 2 m
- Sensor type: KTY 81-210 PVC (cable length 1,5 m)
insulation: -30 °C to 105 °C (adapter set enclosed)

Functional data

- Torque: max 15 Nm
- Rotation time: 73 s / 90°
- Manual override: manual or permanent with pushbutton (for maintenance purposes)
- DIP switches settings: direction of rotation (counterclockwise CCW / clockwise CW); different temperature ranges depending on the application (0÷100 °C, 60÷85 °C, 20÷70 °C, 25÷45 °C); reaction factor x1/x10

Safety

- Protection class: II
- Degree of protection: IP44
- Ambient temperature: 0÷55 °C
- Media temperature: according to valve's specifications
- Storage temperature: -20÷80 °C
- Maintenance: maintenance free

Operation

Front panel description

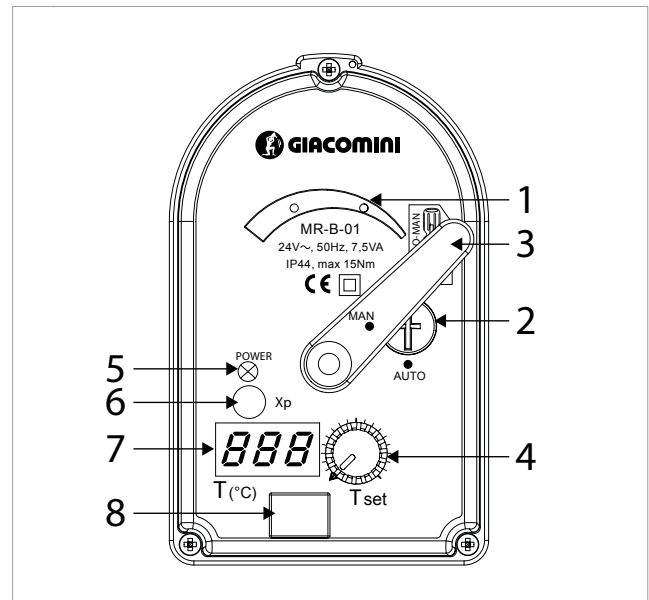

Legend

Number	Description
1	Mechanical indication
2	Button for manual/auto control
3	Handle for manual control, which also serves for the indication of the valve position
4	Button for adjusting the required temperature When adjusting the temperature, the set value flashes on LCD screen
5	LED indication of operation
6	Xp parameter screw cover
7	LCD screen for displaying temperature
8	DIP switches cover

DIP switches and Xp knob are located inside the actuator. They can be set by removing the plastic protection caps on top of the actuator (without removing the red shell).

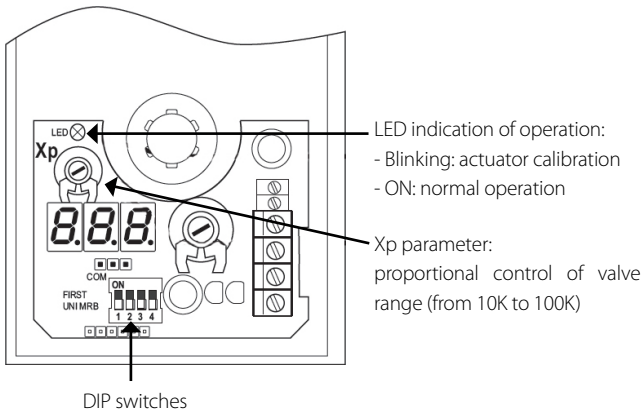

LED indication of operation:
- Blinking: actuator calibration
- ON: normal operation

Xp parameter:
proportional control of valve range (from 10K to 100K)

DIP switches

Factory settings

- DIP1: OFF - way of opening CCW (counterclockwise)
- DIP2, 3: OFF - temperature range 0÷100 °C
- DIP4: OFF: reaction factor x1

DIP switches settings

With DIP switches inside the actuator is possible to set the following parameters:

- DIP1** - Setting direction of valve opening:
ON: opening direction CW (clockwise direction)
OFF: opening direction CCW (counterclockwise direction)
- DIP2, 3** - Different temperature ranges depending on the application (0÷100 °C, 60÷85 °C, 20÷70 °C, 25÷45 °C)
- DIP4** - Reaction factor x1/x10

NB.
Reaction factor x1/x10 - response speed of the actuator. In most cases, the factor x1 is used. x10 factor is recommended in case of installation with a low thermal inertia (PVC pipe, plastic pipes for drinking water).

NB.
Every time the position of DIP1 is changed, actuator calibration is made. The LED blinks (1x/sec) and actuator is rotated to the left and right side. In this case leave the actuator in position AUTO, do not change settings and do not disconnect the power supply. During calibration of actuator system, because of system protection, is necessary to turn off the circulator to prevent oscillation of temperature in the system (underfloor heating, hot water...)

<p>Xp parameter a proportional control range of valve</p>	DIP switch settings														
	<table border="1"> <tr> <th>ON</th> <th>CW</th> <th>CCW</th> </tr> <tr> <td>1 2 3 4</td> <td>1</td> <td>2 3 4</td> </tr> </table>	ON	CW	CCW	1 2 3 4	1	2 3 4	<table border="1"> <tr> <th colspan="2">Temperature range setting</th> </tr> <tr> <td>1</td> <td>2 3 4</td> </tr> </table>		Temperature range setting		1	2 3 4	<table border="1"> <tr> <th>x10</th> </tr> <tr> <td>x1</td> </tr> </table>	x10
ON	CW	CCW													
1 2 3 4	1	2 3 4													
Temperature range setting															
1	2 3 4														
x10															
x1															

<p>ON</p>	Temperature range setting				
	DIP	0°C..100°C	60°C..85°	20°C..70°C	25°C..45°C
1 2 3 4	2	OFF	OFF	ON	ON
	3	OFF	ON	OFF	ON

• Operation to set the DIP switches

- 1) Remove the protection cap from the cover.
- 2) With a small screwdriver move the DIP switches to the desired position.
- 3) Put the protection cap back in its original position.

Xp parameter - proportional valve control area (from 10K to 100K)

With the screw potentiometer inside the actuator can be set reaction factor - parameter Xp. The setting allows actuator adjustment according to the actuator speed response or inertia of the system.

In roughly means, the temperature of regulation range in which the actuator opens or closes completely mixing valve.

For example: to maintain the boiler temperature and for most systems we recommend setting Xp = 50K (factory setting). This means that the actuator will operate in a pulse range of ± 25 °C from set temperature.

During the Xp parameter setup, the set value flashes on the display.

• Operation to set the Xp parameter

- 1) With a screwdriver remove the protection cap from the cover.
- 2) With a screwdriver (max 3 mm), adjust the potentiometer to the desired position. An arrow in the vertical position means Xp = 50K.
- 3) Put the protection cap back in its original position.

Setting desired temperature

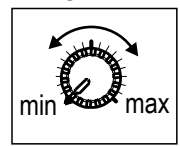

With this knob you can set the desired temperature. Temperature setting range depends on the setting of DIP switches (factory setting is 0÷100 °C).

When the knob is turned, the LED screen displays the set temperature and this value will blink for about 3 seconds.

After that time, the LED screen shows the current sensor temperature.

Manual control

In the case of power failure or for service purposes, user can manually operate with the actuator.

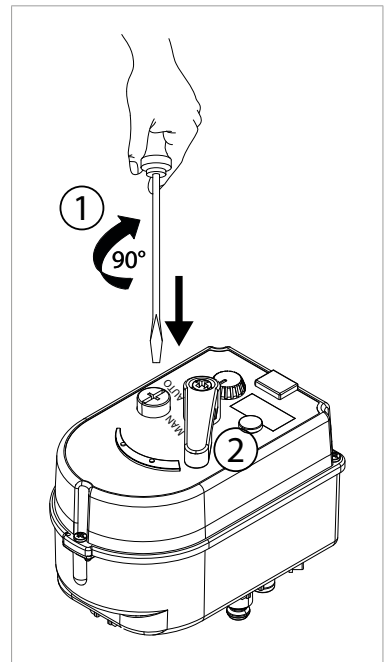

- 1) With a screwdriver push and turn off the button to the MAN position
- 2) Manually move the handle to desired position.

NB.
When the button for manual operation is in MAN position, the actuator stays in temporary position regardless of control signal.

Actuator behavior diagram as a function of temperature (example)

- Desired temperature: 50 °C
- Xp parameter – proportional control range of valve (10K)

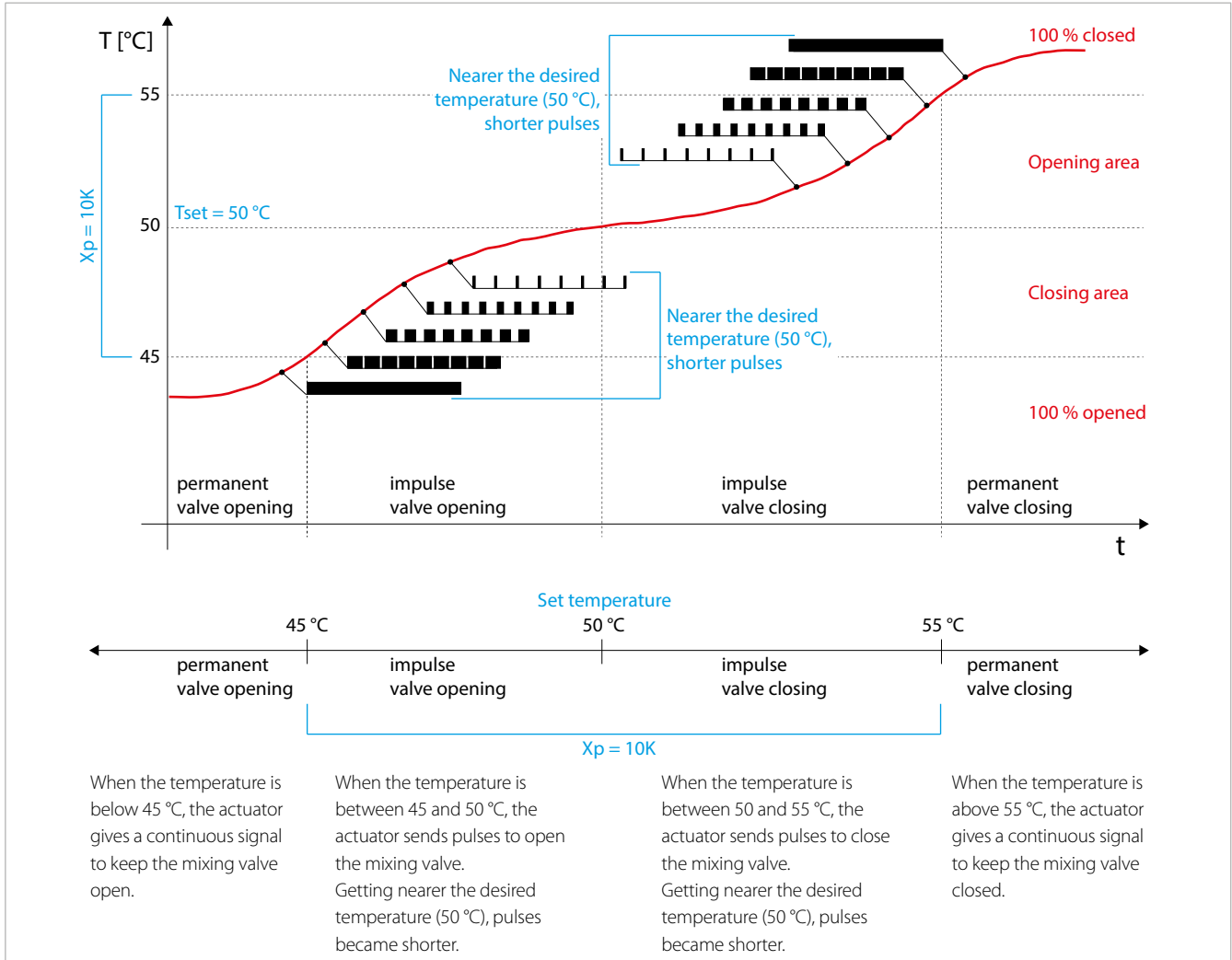

Installation



Note: installation on the valves
To correctly install the K275Y002 actuator on Giacomini valves, refer to the instructions of the valves.

Recommended mounting position

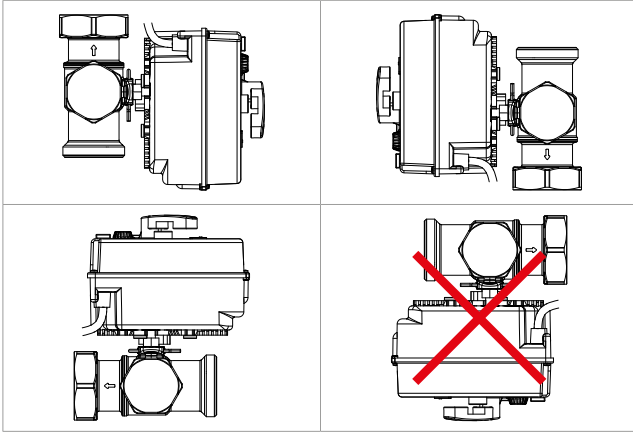

Electrical installation

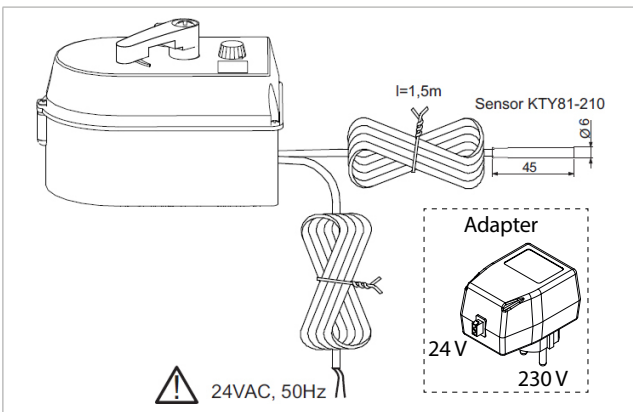

Installation of temperature sensor

The temperature sensor has to be installed after the circulator of the system, at a max. distance of 1,5 m from the actuator.

It can be installed in contact with pipe or as immersion sensor.

- For contact installation use the kit included. It is necessary to provide a flat smooth surface in contact length min. 40 mm for the placing of the sensor. This guarantees max thermal sensor connection and the optimal reaction time of the actuator.

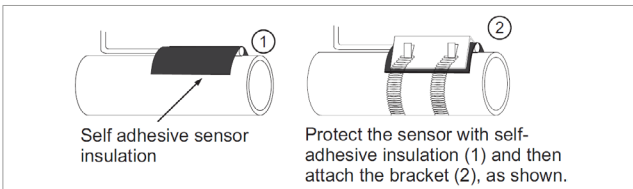

- For immersion installation the sensor must be mounted in sleeve till mid-pipe.

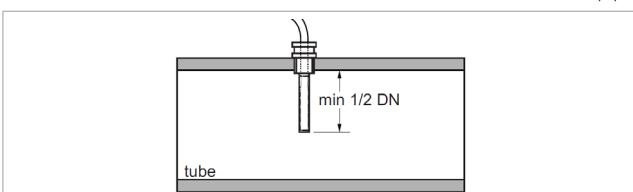

When installing, it is necessary to provide adequate mechanical protection of sensor and sensor's cable. It is necessary to isolate the sensor cable from heat in case of very hot parts.

By optimizing the thermal insulation of the measuring point can eliminate the influence of ambient temperature on the actuator operation.

Operation examples

Underfloor heating

Maintain a constant temperature of heating water.
The installation of a safety thermostat is recommended.

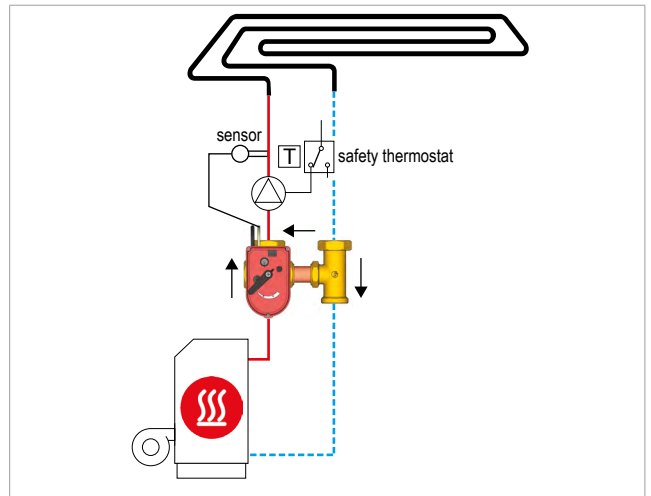

Radiator and underfloor radiant systems

Maintain a constant return flow water temperature (protection against condensation in solid fuel boiler) and constant temperature in the heating system.

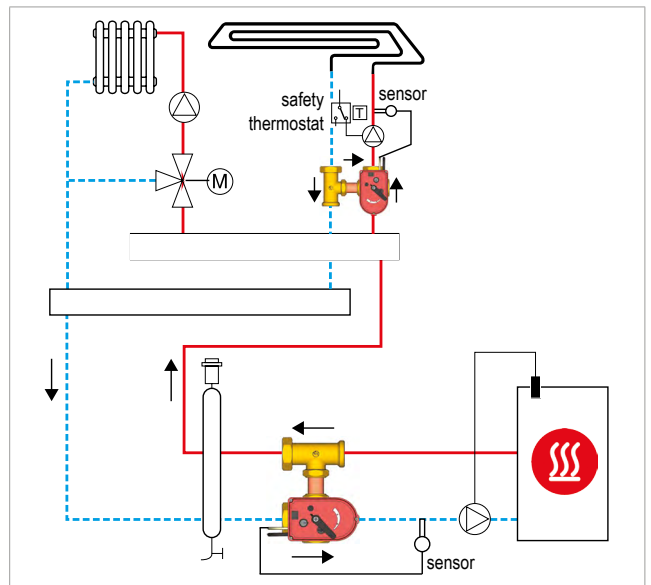

Tank to heat the drinking water

Maintain a constant water temperature inside the hot water tank.

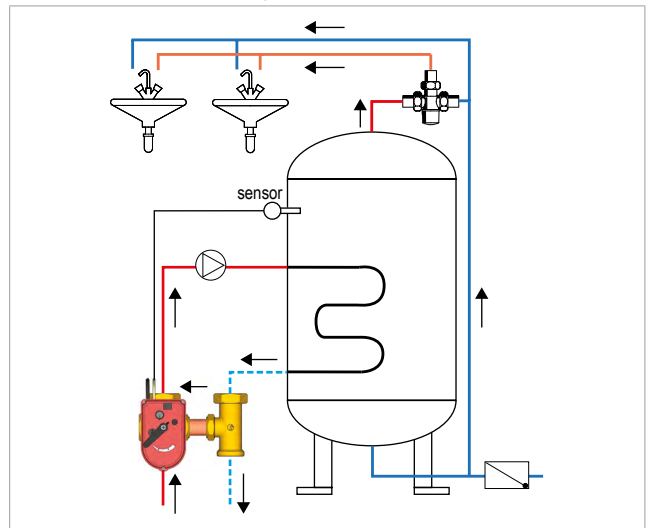



Most common errors

Description of errors	Cause	Repair
On LED screen is displayed: - Er1 - Er2	- sensor is disconnected (Er1) - sensor is in short cut (Er2)	Check the sensor, replace if necessary
Fast blinking of LED diode (2/sec) and on LED display: 888	- low voltage supply	- check the voltage supply
Blinking of LED (1/sec) and rotating of actuator in extreme left and right side	- actuator is calibrating	- leave the actuator calibrating till the end and then will actuator pass in normal operation
Continuous operation of the actuator opening/closing	- Xp factor is set too low	- Xp factor increase to a higher value
	- Xp factor is set too high	- Xp factor decrease to a lower value
	- DIP4 (reaction factor) is in position x10 (too fast response to changes)	- DIP4 switch move to the position x1 (slower response)
Too slow response of actuator or temperature exceeds the desired value	- Xp factor is set too high	- Reduce the value Xp
The actuator does not reach its set value	- sensor is not properly installed (bad contact)	- check the sensor mounting, check if the sensor is thermally insulated
	- AUTO/MAN button of actuator is in a position MAN	- set the button to position AUTO
	- actuator is not properly installed on the mixing valve	- check the actuator mounting on the mixing valve or mechanical installation
If it is necessary to set the temperature to 60 °C, but actuator only allows you to set 45° C	- inappropriate temperature range settings on the DIP switches 2 and 3	- DIP switches 2 and 3 put into right position
The actuator closes the mixing valve but in the system is too cold	- inappropriate set of DIP switch 1	- check the appropriate position of DIP switch 1
The actuator is too slowly responding to the changes, does not reach the desired temperature	- inappropriate set of DIP switch 4 - in the position x1	- for a faster response is necessary to put DIP switch 4 on position x10
LED indicator is not ON, LED display is not illuminated, the actuator stand still	- there is no power	- check power supply
Manual button is in the MAN position, you can not move handle with your hand	- mixing valve is blocked	- remove the actuator from the mixing valve, move the valve axes with tool
The temperature of the system is too low according to the desired temperature or oscillates	- inappropriate sensor insulation from its environment (wind exposure)	- install thermal insulation on the sensor

Safety note

- The actuator has been designed for use in heating, ventilation and cooling systems (NB: without umidity control) and cannot to be used outside the specified field of application, especially in aircraft or in any other airborne means of transport.
- Caution: power supply voltage – 24 VAC.
- It may only be installed by suitably trained personnel. All applicable legal or institutional installation regulations must be complied with.
- The device must be protected from moisture and is not recommended for use in external applications.
- The device may only be opened at the manufacturer's site. It does not contain any part that can be replaced or repaired by the user.
- The cable must not be removed from the device.
- The device contains electrical and electronic components and cannot be disposed as a household refuse. All locally valid regulations and requirements must be observed.

Dimensions

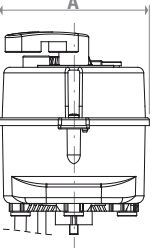
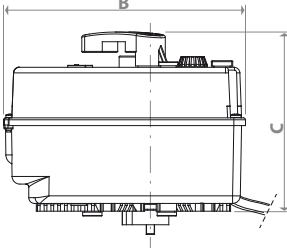
			
Product code	A [mm]	B [mm]	C [mm]
K275Y002	78	125	93

Normative references

- EMC 2004/108/CE
- LV 2006/95/CE
- PAH 2005/69/CE

Additional information

For additional information please check the website www.giacomini.com or contact the technical service: ☎ +39 0322 923372 📠 +39 0322 923255 ✉ consulenza.prodotti@giacomini.com
This pamphlet is merely for information purposes. Giacomini S.p.A. retains the right to make modifications for technical or commercial reasons, without prior notice, to the items described in this pamphlet. The information described in this technical pamphlet does not exempt the user from following carefully the existing regulations and norms on good workmanship.
Giacomini S.p.A. Via per Alzo, 39 - 28017 San Maurizio d'Opaglio (NO) Italy